

Grid:
 ≥ 8,5 mm
 ≥ 335 Mil

MCX Plugs/Jacks see pages 17 - 19

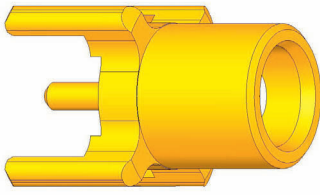

Example: 82 MCX-50-0-19

Note:
 Pre-registration via Outer Conductor.

Centering Area: ± 1,3 mm

Mechanical Data

	Outer Conductor	Inner Conductor
Working Stroke:	4,0 mm	2,0 mm
Maximum Stroke:	5,0 mm	3,7 mm

Spring Force

The Spring-Loaded Inner- and Outer Conductors are available with different Spring Forces. To create the Ordering No. the individual values must be added together (see also „Ordering Example“ below).

Spring Force of Inner Conductor (N)	1,3	2,0	1,3	2,0
Spring Force of Outer Conductor (N)	4,0	4,0	8,0	8,0
Character of ordering	53	60	93	99

Operating Temperature: – 40 up to + 80 °C

Electrical Data

Frequency Range with HFS-810: up to 2 GHz
 Frequency Range with HFS-840: up to 4 GHz

Current Rating

Outer Conductor: 8–10 A
 Inner Conductor: 2–3 A
 R_i typical Inner Conductor: ≤ 10 m Ω
 Impedance Test Probe: 50 Ω
 Impedance Cable: 50 Ω

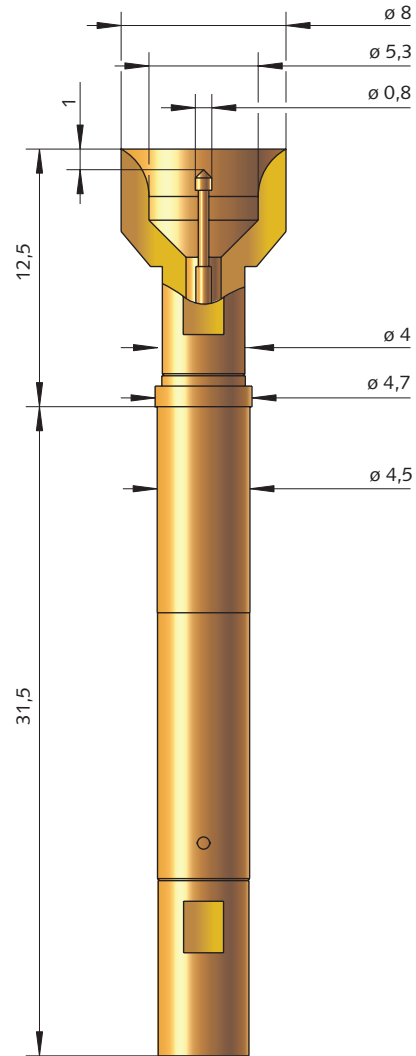

Typical Return Loss HFS-840 308 080 A 5343 X

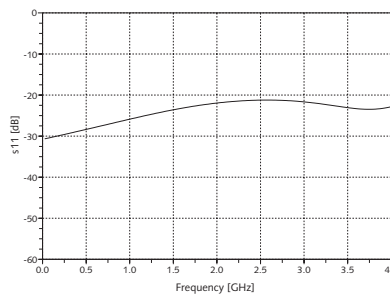

Typical Insertion Loss HFS-840 308 080 A 5343 X

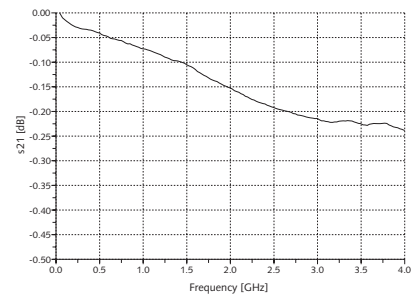

Ordering Example:

Series	Tip Material 2 = Steel 3 = BeCu	Tip Style	Tip Diameter (1/100 mm)	Plating A = Gold	Spring Force (dN)	Outer-Plunger	Type
--------	---------------------------------------	-----------	----------------------------	---------------------	----------------------	---------------	------

Test Probe for Frequency Range up to 2 GHz:

HFS 810 3 08 080 A 53 43 X

Test Probe for Frequency Range up to 4 GHz:

HFS 840 3 08 080 A 53 43 X

MCX-Connector with RF-Coaxial Cable RG 316 / U pre-wired, length 0,7 m (Special lengths on request):
 Receptacle:

SE-810 V-U (Grid >5,08 mm) SE-810 V (Grid 5,08 mm)
 KS - 810

Further Information see page „Accessories“.

All specifications are subject to change without prior notification

HFS-810/840
 HFS-810 M
 HFS-840 M