

# HFS-810 / HFS-840

1.0/2.3 Contacting

**Grid:**  
 ≥ 6,5 mm  
 ≥ 256 Mil

1.0/2.3 Plugs/Jacks see pages 31 - 32

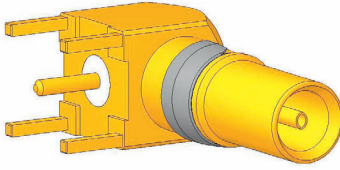

Example: 85 1023-C50-0-1

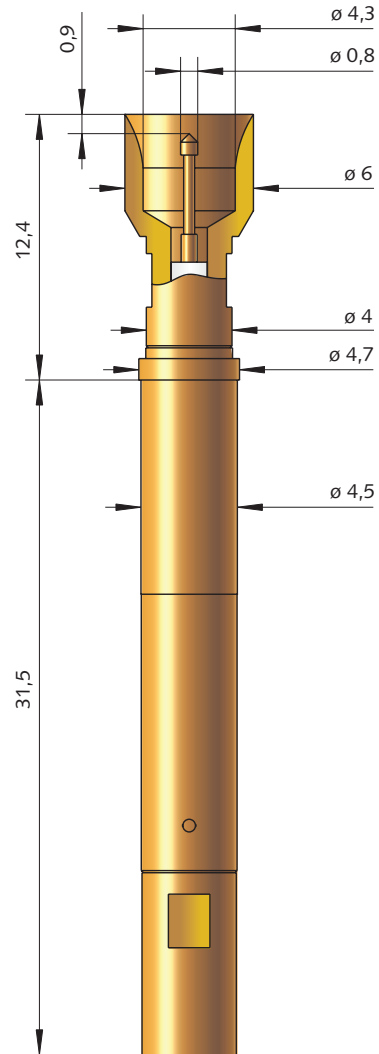

**Centering Area:** ± 0,6 mm

**Mechanical Data**

	Outer Conductor	Inner Conductor
Working Stroke:	4,0 mm	2,0 mm
Maximum Stroke:	5,0 mm	3,7 mm

**Spring Force**

The Spring-Loaded Inner- and Outer Conductors are available with different Spring Forces. To create the Ordering No. the individual values must be added together (see also „Ordering Example“ below).

Spring Force of Inner Conductor (N)	1,3	2,0	1,3	2,0
Spring Force of Outer Conductor (N)	4,0	4,0	8,0	8,0
Character of ordering	53	60	93	99

**Operating Temperature:** – 40 up to + 80 °C

**Electrical Data**

Frequency Range with HFS-810: up to 2 GHz  
 Frequency Range with HFS-840: up to 4 GHz

**Current Rating**

Outer Conductor:	8–10 A
Inner Conductor:	2–3 A
R <sub>1</sub> typical Inner Conductor:	≤ 10 m Ω
Impedance Test Probe:	50 Ω
Impedance Cable:	50 Ω

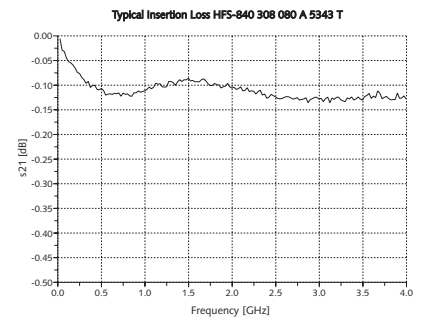
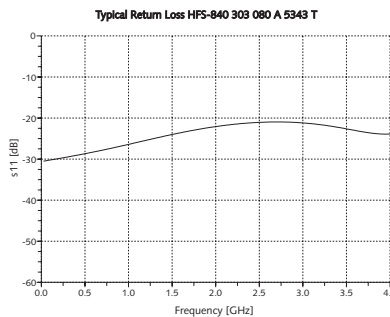

**Ordering Example:**

Series	Tip Material 2 = Steel 3 = BeCu	Tip Style	Tip Diameter (1/100 mm)	Plating A = Gold	Spring Force (dN)	Outer-Plunger	Type
--------	---------------------------------------	-----------	----------------------------	---------------------	----------------------	---------------	------

Test Probe for Frequency Range up to 2 GHz:

HFS 810 3 08 080 A 53 43 T

Test Probe for Frequency Range up to 4 GHz:

HFS 840 3 08 080 A 53 43 T

MCX-Connector with RF-Coaxial Cable RG 316 / U pre-wired, length 0,7 m (Special lengths on request):  
 Receptacle:

SE-810 V-U (Grid >5,08 mm) SE-810 V (Grid 5,08 mm)

KS - 810

Further Information see page „Accessories“.